

features

- Multi-protocol
- Modular concept
- Simple, robust design
- Intuitive to use
- Easy to maintain
- Easy to expand
- Easy to network
- Easy to install
- Easy to configure

The ZX5e is an intelligent fire alarm control panel. It has been designed and is constructed around proven and reliable microprocessor technology. This simple approach has produced a modular, scaleable fire alarm platform suitable for protecting all types of premises.

The ZX5e control panel supports a total of five industry leading protocols, allowing fire detection devices to be independently selected based on performance or aesthetic appeal. The ZX series control panels seamlessly integrates with Apollo (Xplorer, XP95 & Discovery), Hochiki ESP, Nittan, Morley-IAS and System Sensor detection device protocols.

Designed for maximum flexibility the ZX5e control panel is supported by a complete suite of peripherals and software tools. Information on the location of fires, faults and system status can easily be displayed or printed in multiple locations. Integration to Voice Evacuation Systems, paging systems and third party control systems is supported through a range of peripheral interface units.

This adaptability, support and intelligence means that the ZX5e is suitable for new projects, system

expansions, retrofits and system upgrades in all application areas. Offices, industrial units, multi-storey buildings, entertainment venues, industrial plants and hospitals are a few of the many applications that can benefit from the features of the ZX5e intelligent multi-protocol fire alarm control panel.

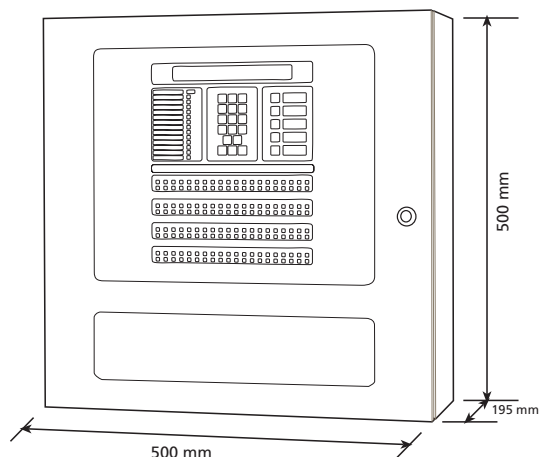

Charles Avenue, Burgess Hill
West Sussex, RH15 9UF
United Kingdom

Tel: +44 (0) 1444 23 55 56
Fax: +44 (0) 1444 25 44 10
Email: sales@morleyias.co.uk
www.morley-ias.co.uk



ZX5e Multi-protocol Fire Alarm Control Panel Data Sheet



system

The ZX5e control panel forms the heart of the fire detection system. A steel enclosure contains all the required components – microprocessor, power supply plus a clear LCD (Liquid Crystal Display), system status indicators and the control buttons that are the user interface.

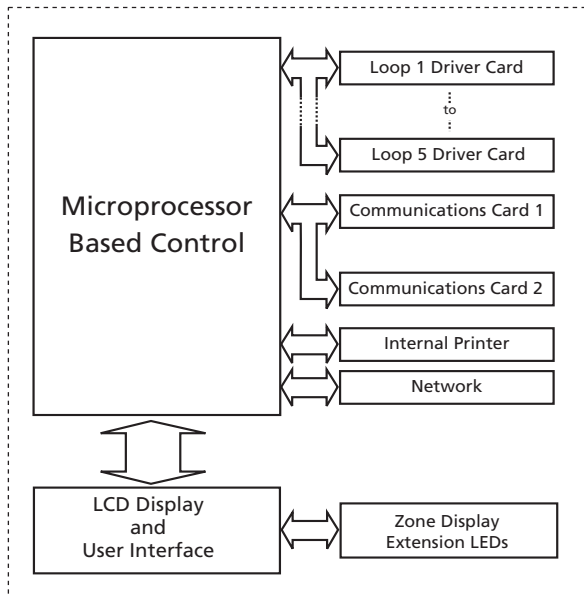

A quick glance enables users to assess the condition of the fire alarm system. Alarm and Fault conditions are highlighted by LEDs and supported by enhanced text descriptions on the LCD display. Clearly labeled buttons allow users to quickly manipulate the system providing both audible and tactile feedback of successful operations.

Accidental operation is prevented by user passcodes that are required to gain access to functions. Basic functions (Evacuate, Reset, Mute, Accept, Silence) are available at one access level whilst more advanced operations are protected by a secondary level passcode. Individual device isolations, test modes and configuration data are all protected by these secondary access levels.

Inside each control panel the microprocessor maintains a log of the events or actions occurring on the system. Fires, Faults, tested devices and diagnostics are all electronically logged for future reference. Remote (or local) printers can easily be connected to provide a paper copy of events as and when they occur or provide a historical record.

The control panel can be configured to support any one of the five detection protocols by installing the correct loop driver cards in the control panel. For each loop the control panel will support a total up to 126 devices using Apollo, Hochiki or Nittan protocols and up to a maximum of 99 sensors and 99 modules (call points, monitor, control, conventional zone modules and addressable sounders) using the Morley-IAS or System Sensor protocols.

The flexibility of the ZX5e design allows the control panel to be connected to a wide variety of peripheral devices. From display repeaters to custom mimic displays, printers, serial data interfaces and switching relay interfaces.

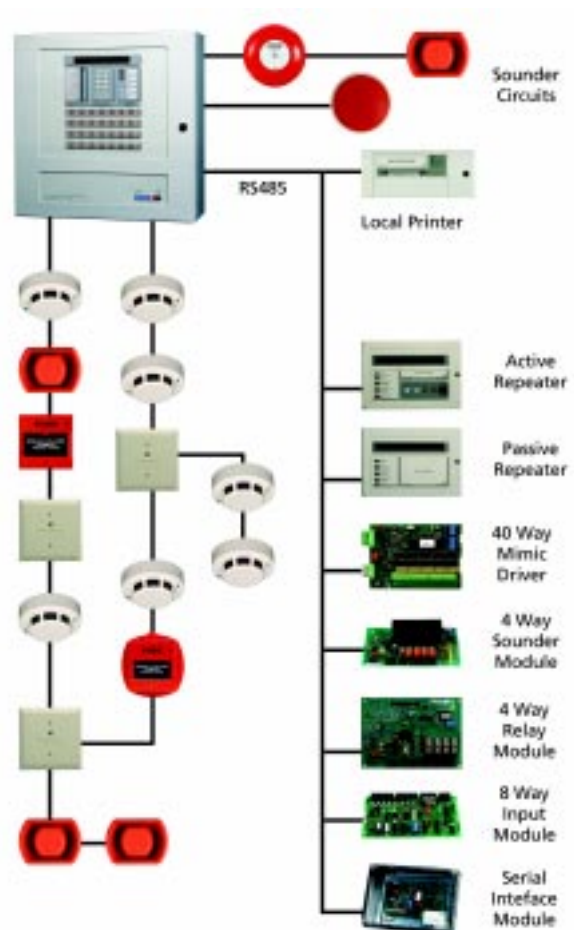

installation

The initial installation of the system is aided by sophisticated features like AUTOLEARN. An internal routine that will automatically detect all the devices on the detection and peripheral loops saving the time of entering all the devices individually.

Basic programming is also configured during the Autolearn process resulting in only fine tuning of the system being required to complete the system configuration.

An off-line Windows™ configuration tool is available to further enhance the process, making text entry and specific device programming easier. Complex cause and effects programming

is simplified through clearly designed user interfaces. Once completed the configuration of the panel can be saved for future reference. Enhanced features allow the complete archiving of the control panel history log and a Virtual Panel Interface enables all control commands to be entered using the computer.



maintenance

The ZX5e intelligent fire alarm control panel has been designed to help with the normal operation of a fire detection system. Standard weekly testing is available through a simple menu structure allowing selection of the zones to be tested and the optional activation of the outputs or ringing of the sounders.

The status of individual devices can be analysed to determine whether cleaning or replacement is required. This information can either be viewed directly on the LCD or printed for reference.

As the installation grows the ZX5e can expand with the installation, adding additional devices, loop cards, printers, display repeaters or interface devices. If the installation becomes too big for a ZX5e, additional ZX2e or ZX5e control panels can simply be added by networking using two or more control panels together.

networking

The Morley-IAS network is unique. A clever protocol allows for the propagation and distribution of all messages and control signalling. A robust protocol that can be used over long distances, even on MICC, mineral based fire resistant cabling. The ZX5e can be networked with other ZX series control panels using Master/Slave architecture. Up to a maximum of 99 control panels can be networked together using the standard control panel operating system. The network can be configured in two ways:

For single sites or large buildings the networking

is normally configured as one large system. Each networked control panel shares information. Alarms and communications are reported to each individual display.

If the fire alarm system is to provide cover for multiple buildings or multiple sites it is normally configured to operate in a report and control mode. The fire alarm panels act individually or as sub-systems only reporting information to the master on the level above.

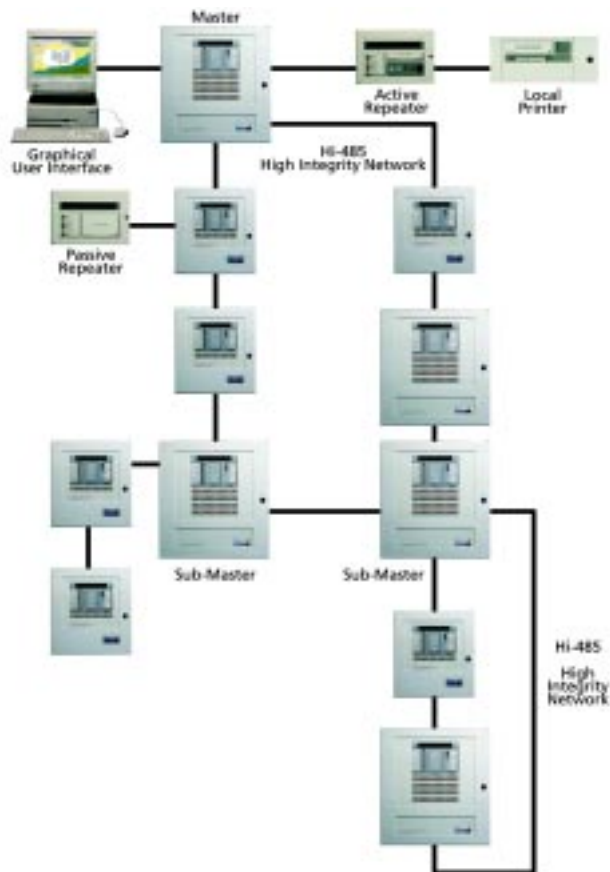

specification

Operating Voltage:	230V 50Hz AC (+10%, -15% voltage tolerance)	keys:	with 15 keys and three control YES, NO
Max. PSU Rating:	3.25 Amps total, comprising:	(CANCEL/ESC), and ENTER	
Battery Charger:	1.0 Amps	LED type general panel status indicators:	FIRE, FAULT, ACCEPTED, DISABLEMENT, TEST, SOUNDER FAULT, DELAYED MODE, RELAYS DISABLED, EARTH FAULT, SYSTEM/CPU FAULT, SOUNDERS DISABLED, ALARMS SILENCED, SUPPLY FAULT, POWER.
Internal & External Loads:	2.25 Amps	LED type zone Indicators (for 20 zones):	FIRE, FAULT/TEST/DISABLED
Standby Batteries:	24V sealed lead acid batteries	Display:	2x40-character LCD alphanumeric display with back-light.
Minimum Capacity:	2x 12V 12Ah (internally fitted)	Serial Interface:	3 serial ports with connections for optional RS485 or RS232 plug-in communication cards.
Maximum Capacity:	2x 12V 25Ah (internally fitted)	Networking:	Maximum 99 panels can be networked using a Master Network and connected Sub- Networks.
Power Supply:		Approvals:	CE LPCB certification pending
Input(s):	24V and 7VAC (from integral mains transformer)		
Output(s):	24V nominal (25.5 - 20.0V)		
Dimensions (mm):	500 x 500 x 195 (H x W x D)		
Weight:	19.0 kg without batteries 38.2 kg with 2x 25Ah batteries		
Environmental Operating Limits:			
Temperature:	0°C to +40°C		
Humidity:	85% non-condensing (maximum)		
Construction:	Sheet steel painted, sealed to IP30		
Cable Entry:	24 x 20mm knock-outs in top of cabinet 24 x 20mm knock-outs in bottom of cabinet		
Loop Capacity:	1 to 5 loops expandable		
Apollo, Nittan and Hochiki Protocols:	Max. 126 devices (detectors and modules) per loop		
Morley-IAS and System Sensor Protocols:	Max. 99 sensor and 99 module addresses per loop		
Note :	Multitple sensor protocols cannot be used in the panel simultaneously.		
Zones:	Up to 20 zone with individual LED indicators.	721-001-001	ZX5e Fire Alarm Control Panel (English)
Expandable to 40 or 80 individual LED indicators. A maximum 200 can be programmed with up to 120 software zones with no LED indication.		721-001-201	ZX5e Fire Alarm Control Panel (Unbranded)
Internal Sounder:	Intermittent buzzer (fault condition) High-pitched continuous buzzer (fire condition)	795-066	Apollo XP95 & Discovery Loop Driver Card
External Outputs:		795-048	Apollo S90 Loop Driver Card
Sounder Outputs:	4 programmable outputs. Open and short circuit monitoring. 1A maximum per output.	795-058-005	Hochiki ESP Loop Driver Card
Auxiliary Relays:	EN54 format at 1 fault relay and 1 programmable relay voltage free, changeover outputs Contacts rated at 24V AC/DC, 1A, 0.6 pF maximum.	795-044-001	Nittan Loop Driver Card
User Controls:	MUTE, ACCEPT, SILENCE/RESOUND, SOUND ALARMS & RESET	795-068	System Sensor Loop Driver Card
Programming Controls:	Alphanumeric multi-level keypad	795-005	RS232 Communication Card
		795-004-001	RS485 Communication Card
		795-077-020	20 Zone LED Display Indicator Card
		795-077-060	60 Zone LED Display Indicator Card
		795-051-001	Internal Printer
		797-062	Bezel kit for ZX5e
		795-078	Fire 6 Windows™ Configuration Tool
		795-079	Programming interface lead & Fire 6 Windows™ Configuration Tool
		795-014	4 way programmable relay module, pcb only.
		795-015	4 way programmable sounder module, pcb only.
		795-029	8 way programmable input module, pcb only.
		795-038-001	Hi-485 communication module, pcb only.
		795-065	40 way programmable mimic interface module, pcb only.
		709-001	ZXR5B Active Repeater. LCD, System Status indicators and user controls for Silence, Reset, Mute and Evacuate all activated by a key switch.
		709-101	ZXR4B Passive Repeater. LCD and system status indicators.
		797-059	Bezel kit for ZXE4B and ZXR5B.
		795-060-002	External remote printer module.

part numbers